



RECONSTRUCTION

TORNOS AS14, SAS16 et SAS16DC

Variation cam Spindle
Thread milling CNC
Slide CNC
Pickup CNC

NEW
CROSSED SLIDES
2 AXIS CNC IN STATION 4

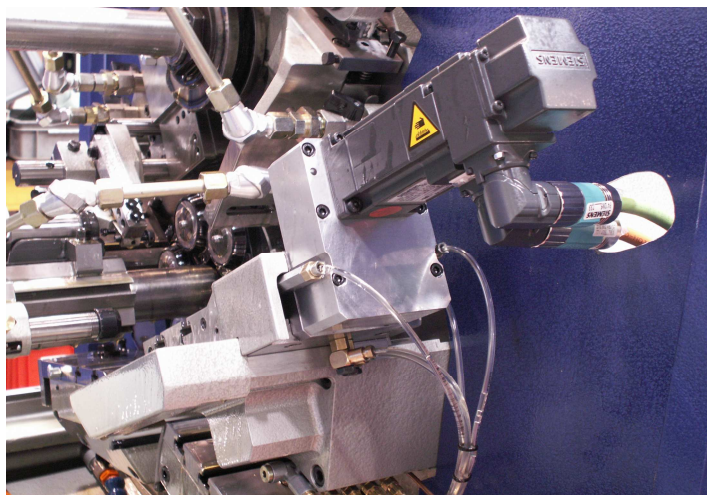
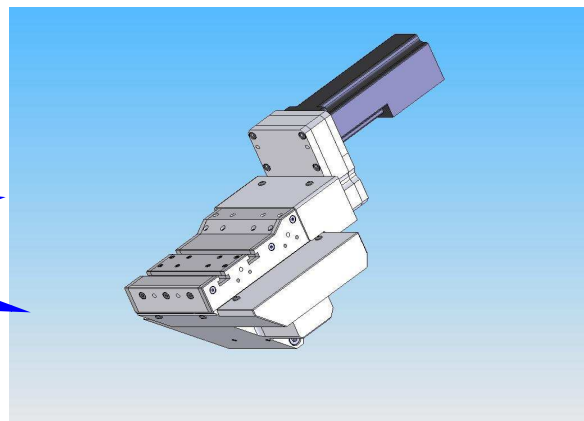

Technical characteristics in station 4

Standard stroke Axis X	25 mm
Max linear speed Axis X	10 m/mn
Standard stroke Axis Z	50 mm
Max linear speed Axis Z	15 m/mn
Strength of push on the Axis	2000 N
Resolution	1 μ
Ball screw with preforced nut	
Guiding on preforced ball rails	
Complete centralized greasing	

Using standard tool holders - Minimum dimensions - Visual access operator